

MechaTron[®] “MC” 3-A Feeder

- 3-A accepted feeder for food, dairy, and sanitary feeding applications
- Crack and crevice-free contact surfaces
- FDA compliant internal feed hopper
- Volumetric and gravimetric configurations for feed rates up to 330 cu. ft. (9,300 liters) per hour



Materials of Construction

Contact materials –

- 304 & 316 stainless steel and 3-A sanitary polymers (Nylon, Rulon, and Silicone)
- Coni-Flex™ 3-A sanitary white polyurethane feed hopper

Non-contact materials –

- 304 stainless steel and epoxy coated cast aluminum

Feed Rates

- Feed rates from 0.30 to 330 cubic feet (8.5 to 9,300 liters per hour, theoretical)

Feed Screws

- Wound helix diameters from 1.00" (25 mm) to 3.5" (89 mm)
- 304 or 316 stainless steel construction
- Single screw open flight or machined screw configurations
- Full pitch and half pitch configurations
- Extensions to 42" (1.1 meters) from the feeder face with end discharge

Coni-Flex™ Feed Hopper

- Removable 70 degree (from horizontal) conical flexible internal feed hopper
- 1.2 cubic feet (35 liters) of material storage capacity
- FDA compliant polyurethane

Hopper Extensions

- 2.5, 7.5, and 13.2 cubic feet (75 to 375 liters) capacities with domed auto refill cover 10" (250 mm) inlet and 4" (100 mm)

vent connections, domed manual cover (no inlet/vent), or no cover

- Dust tight 360 degree band clamp mounting

Motor Specifications

- Single and dual AC (TENV 1 HP and 1/2 HP inverter duty) wash-down duty configurations
- 230/460 VAC, 3Ø 50/60 Hz

Mounting Configurations

- Floor mount - 304 stainless steel tubular stand designed to 3-A sanitary standards

Weigh Module Specifications (optional)

- Dual Schenck stainless steel strain gage load cells. No summing box required.
- Weigh modules available in 264 lbs. (120 kg), 441 lbs. (200 kg), 662 lbs. (300 kg), and 1,324 lbs. (600 kg) capacities

Performance

- 2 Sigma accuracies of $\pm 2\%$ to 5% of feed rate setpoint are typical in volumetric configurations. Testing is recommended to assess material specific performance.
- 2 Sigma accuracies of $\pm 1/4\%$ to 1/2% of feed rate setpoint are typical in gravimetric configurations. Testing is recommended to assess material specific performance.

NOTE: Laboratory testing to determine specific material feeding accuracy is recommended and available from Schenck Process.

3-A Sanitary Feeder

Volumetric and gravimetric (weight-controlled) configurations available.

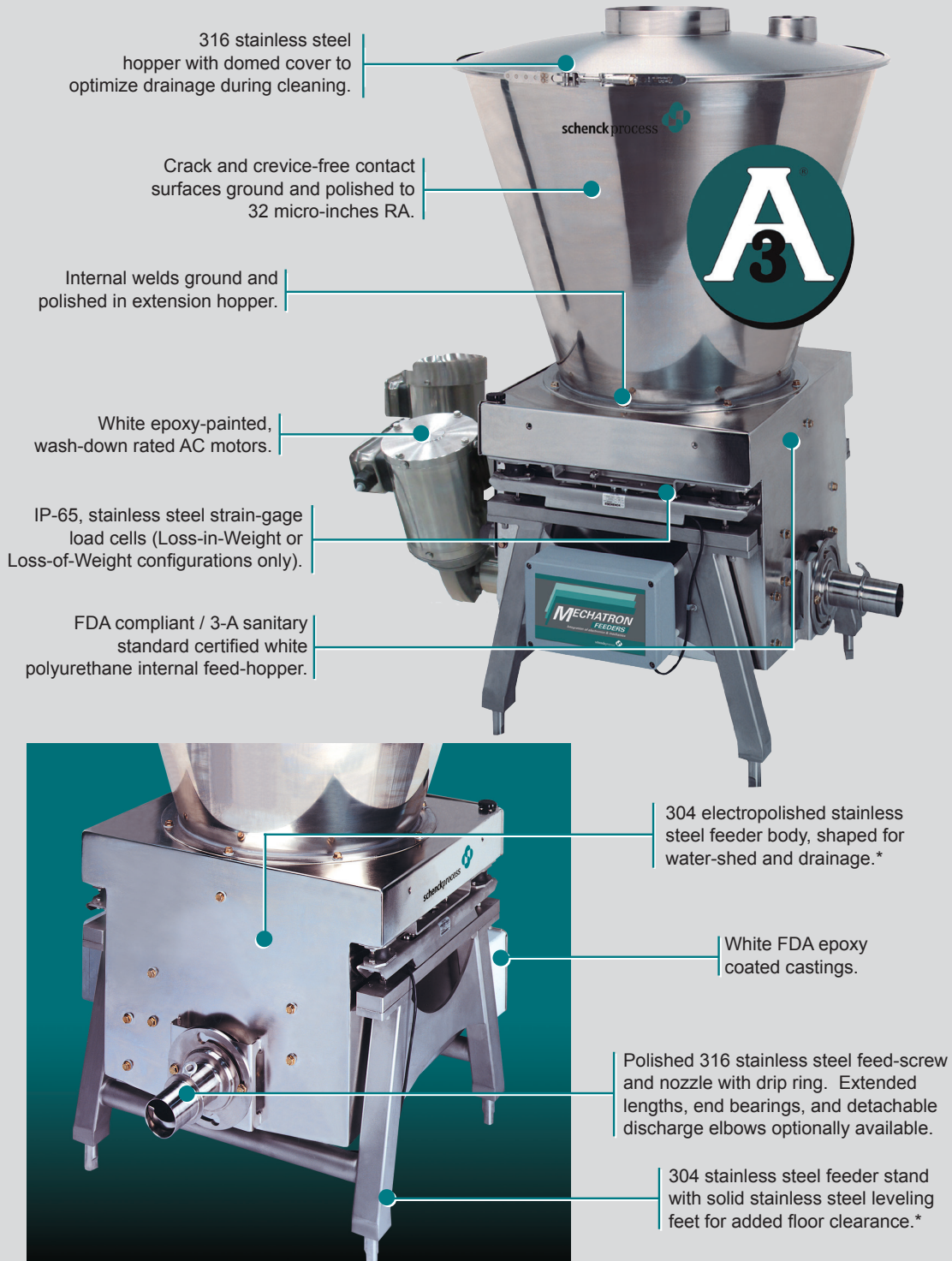

316 stainless steel hopper with domed cover to optimize drainage during cleaning.

Crack and crevice-free contact surfaces ground and polished to 32 micro-inches RA.

Internal welds ground and polished in extension hopper.

White epoxy-painted, wash-down rated AC motors.

IP-65, stainless steel strain-gage load cells (Loss-in-Weight or Loss-of-Weight configurations only).

FDA compliant / 3-A sanitary standard certified white polyurethane internal feed-hopper.

304 electropolished stainless steel feeder body, shaped for water-shed and drainage.*

White FDA epoxy coated castings.

Polished 316 stainless steel feed-screw and nozzle with drip ring. Extended lengths, end bearings, and detachable discharge elbows optionally available.

304 stainless steel feeder stand with solid stainless steel leveling feet for added floor clearance.*

NOTE: Electropolishing, passivation, and other surface preparations are optionally available.
* 316 or 316L stainless steel is optionally available.

A feeder you can quickly reconfigure, clean or service from the non-process side.



1 All internal components are accessible from the rear of the feeder instead of the discharge side. Simply remove back panel and loosen swivel assembly bolt.

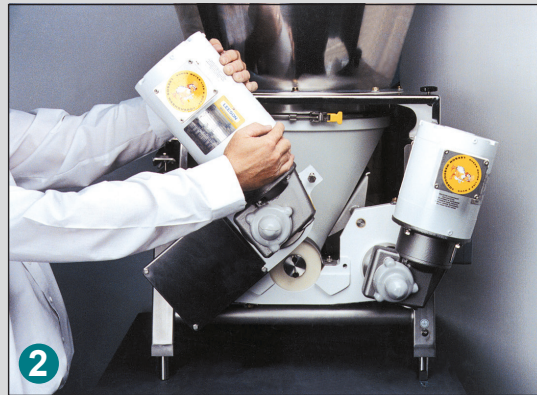

2 Motor and drive assembly swings to the side for complete access to all internal components for easy cleaning, reconfiguration or maintenance.



3 Helix is easily removed allowing for fast and easy helix cleaning and changeover.



4 Release band clamp lever for hopper removal.



5 Hopper slides out for cleaning, replacement or maintenance.



6 Reposition motor and drive assembly. Tighten swivel assembly bolt, replace back panel cover, and you're ready to run – all in under two minutes.

Dimensions

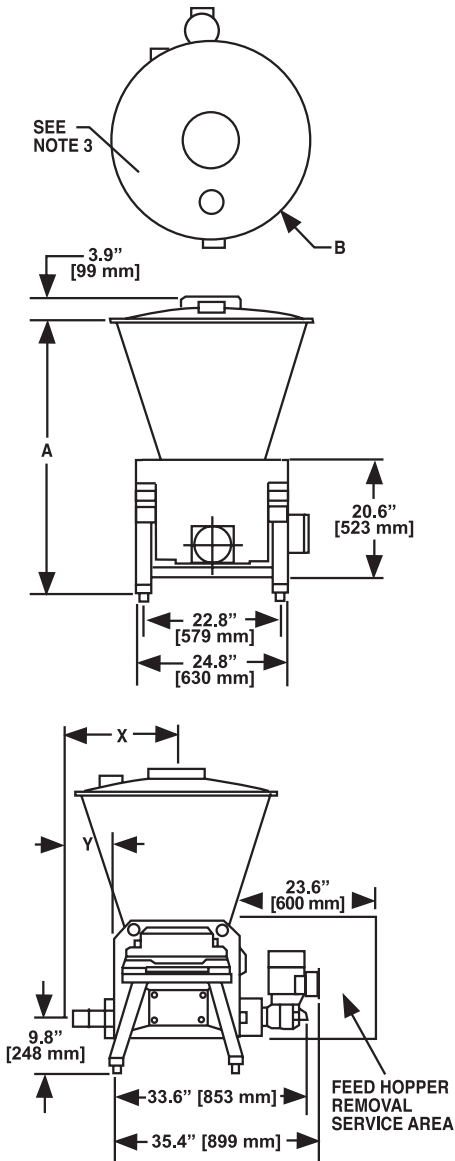

NOTE: Dimensions subject to change without notice. Please contact sales for detailed drawings.

Schenck Process
 746 E. Milwaukee Street
 Whitewater, WI 53190
 262-473-2441
 sales-fcp@schenckprocess.com
 www.schenckprocess.com/us

FEEDER (Dead Load)	Weight	Hopper Capacity
Single Drive	194 lbs. (88 kg)	1.2 cu. ft. (35 L)
Dual Drive	209 lbs. (95 kg)	

EXTENSION HOPPERS	Weight	Hopper Capacity
75 L	16 lbs. (7 kg)	2.5 cu. ft. (75 L)
210 L	28 lbs. (13 kg)	7.5 cu. ft. (210 L)
375 L	55 lbs. (25 kg)	13.2 cu. ft. (375 L)

COVERS	Weight
75 L	15 lbs. (7 kg)
210 L	25 lbs. (11 kg)
375 L	25 lbs. (11 kg)

TOTALS (Based on single drive)	Weight	Hopper Capacity
Feeder + 75 L + cover	225 lbs. (102 kg)	
Feeder + 210 L + cover	247 lbs. (112 kg)	
Feeder + 375 L + cover	274 lbs. (124 kg)	
Stand + Feeder + 75 L + cover	314 lbs. (142 kg)	3.7 cu. ft. (110 L)
Stand + Feeder + 210 L + cover	336 lbs. (152 kg)	8.7 cu. ft. (245 L)
Stand + Feeder + 375 L + cover	363 lbs. (165 kg)	14.4 cu. ft. (410 L)

NOTES:

- Standard infeed to discharge (X) is 19.7" (500 mm), with extensions to 42" (1,066 mm) from front face of feeder in one-inch increments. Standard distance from front face of feeder (Y) is 7" (178 mm) for helix diameter of 1.75" (44 mm) or larger and 8" (203 mm) for helix diameter of 1.38" (35 mm) or smaller. Minimum full pitch helix is 1.00" (25 mm); 1/2 pitch flighting minimum diameter is 1.38" (35 mm).
- System Scale Capacity:
 Total (2 Load Cells)
 264 lbs. (120 kg) 441 lbs. (200 kg)
 662 lbs. (300 kg) 1,324 lbs. (600 kg)
- Domed cover is available in auto refill (shown), manual refill or with no cover. Domed cover may be rotated up to 360° to meet application requirements. Standard inlet and vent is 10" inlet (254 mm) and 4" vent (102 mm).
- Motors available: .5 HP (.37 kW) or 1 HP (.75 kW), IP-55 wash-down duty, TENV, meets NEMA MG-1 (parts 30 & 31).
- Electrical service requirements:
 230V, 3 phase, 16.2 amps max. full load current, 50/60 Hz
 -or-
 460V, 3 phase, 7.1 amps max. full load current, 50/60 Hz

EXTENSION HOPPER DIMENSIONS

Capacity	Dim "A"	Dim "B"
2.5 cu. ft. (75 L)	35.1" (892 mm)	26.7" (677 mm)
7.5 cu. ft. (210 L)	47.2" (1,199 mm)	34.1" (866 mm)
13.2 cu. ft. (375 L)	59.1" (1,500 mm)	34.1" (866 mm)

