

MechaTron[®] “LC” Feeder

- Volumetric and gravimetric configurations for feed rates up to 21 cu. ft. (595 liters) per hour
- Agitation of a Coni-Flex™ conical flexible internal feed hopper eases material handling
- Disassembly from the non-process side of the feeder simplifies cleaning, servicing, and reconfiguration
- Perfectly suited for dry material feeding applications in all process industries

Materials of Construction

Contact materials –

- 304 & 316 stainless steel and UHMW PE
- Coni-Flex™ chemical duty FDA approved gray and white vinyl
- Coni-Flex™ chemical duty and static dissipative polyurethane

Non-contact materials –

- 304 stainless steel and epoxy coated cast aluminum

Feed Rates

- Helix diameters from .25” (6 mm) to 1.38” (35 mm)
- Theoretical feed rates from 0.002 to 21 cubic feet (.057 to 595 liters) per hour

Feed Screws

- 304 or 316 stainless steel
- Single screw, open flight or center rod configurations
- Full or half pitch configurations
- Extensions from 12” (300 mm) to 48” (1.2 meters) from the feeder face (actual maximums are helix diameter dependent)

Coni-Flex™ Feed Hopper

- Removable 70 degree (from horizontal) conical flexible internal feed hopper
- .25 cubic feet (7.4 liters) of material storage capacity

Hopper Extensions

- 1, 2.3, and 3 cubic feet (30, 65, and 83 liters) capacities with or without 5” (127 mm) inlet and 3” (76 mm) vent connections
- Dust tight 360 degree band clamp mounting

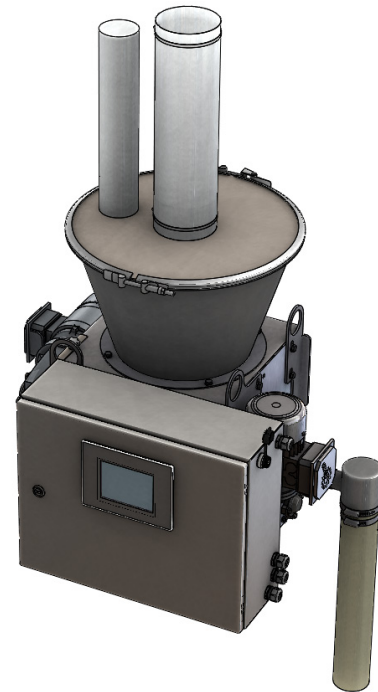

Motor Specifications

- Industrial applications, helix drive – 1/2 HP (.37 kW) AC, TEFC, inverter duty
- Industrial applications, agitation drive – 1/6 HP (.12 kW) AC, TEFC, inverter duty (used in dual motor feeder configurations only)
- 230/460 VAC, 3 PH, 60 Hz

NOTE: Wash-down duty rated motors are used in feeders intended for food and pharmaceutical applications.

Mounting Configurations

- Floor mount – 304 stainless steel tubular stand





Weigh Module Specifications (optional)

- Dual Schenck stainless steel strain gage load cells. No summing box required.
- Weigh modules available in 132 lbs. (60 kg), 264 lbs. (120 kg), and 441 lbs. (200 kg) capacities

Performance

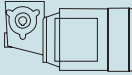
- Volumetric accuracies of +/- 2% to 5% of feed rate setpoint at 2 sigma
- Gravimetric accuracies of +/- 1/4% to 1% of feed rate setpoint at 2 sigma

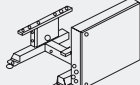
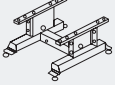
NOTE: Laboratory testing to determine specific material feeding accuracy is recommended and available from Schenck Process.

EXTENSION HOPPER	MAINFRAME	SINGLE/DUAL DRIVE	GEAR RATIO	MOTORS	CONTROL	GRAVIMETRIC/ VOLUMETRIC
<p>No Cover</p> <p>Manual Cover</p> <p>No Extension</p>	<p>Gray Vinyl</p>					<p>Gravimetric</p> 
<p>No Cover</p> <p>Manual Cover</p> <p>Auto Cover</p> <p>1.0 cu. ft. (30 Liter)</p>	<p>White Vinyl</p>				<p>Mechatronic</p>  <p>Remote</p> 	<p>2@ 66 lbs. (30 kg)</p> <p>2@ 132 lbs. (60 kg)</p> <p>2@ 220 lbs. (100 kg)</p>
<p>No Cover</p> <p>Manual Cover</p> <p>Auto Cover</p> <p>2.3 cu. ft. (65 Liter)</p>	<p>Toner Resistant</p>			<p>(optional) 0.5 hp 50 Hz</p> <p>0.5 hp 60 Hz</p> <p>Helix</p>	<p>Hanging (optional)</p>	
<p>No Cover</p> <p>Manual Cover</p> <p>Auto Cover</p> <p>3.0 cu. ft. (83 Liter)</p>	<p>Static Dissipative</p>	<p>Dual</p> 		<p>(optional) 0.16 hp 50 Hz</p> <p>0.16 hp 60 Hz</p> <p>Agitation</p>		<p>Volumetric</p> 

A feeder you can quickly reconfigure, clean or service from the non-process side.

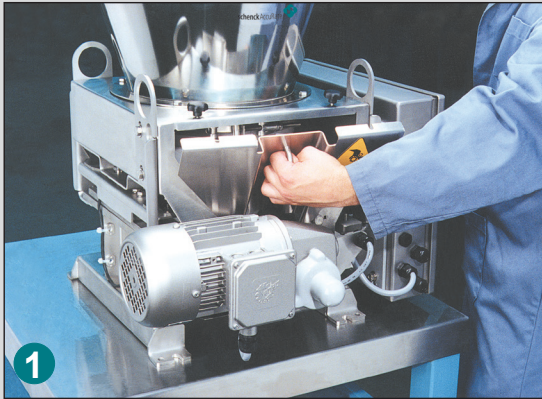

1 All components are accessible from the rear of the feeder instead of the discharge side. Simply loosen screw knobs and remove backplate.

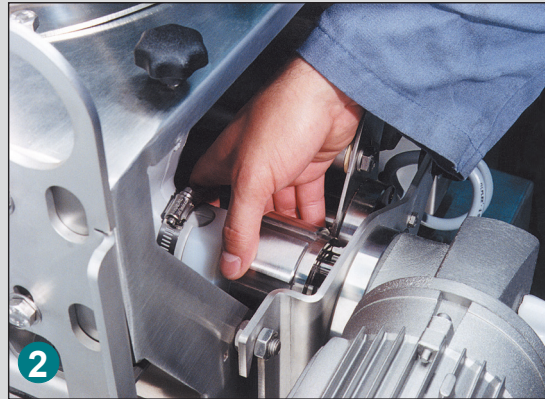

2 Loosen swivel stop bolt and quill nut.



3 Motor and drive assembly swings back for complete access to all internal components for easy cleaning, reconfiguration, or maintenance.

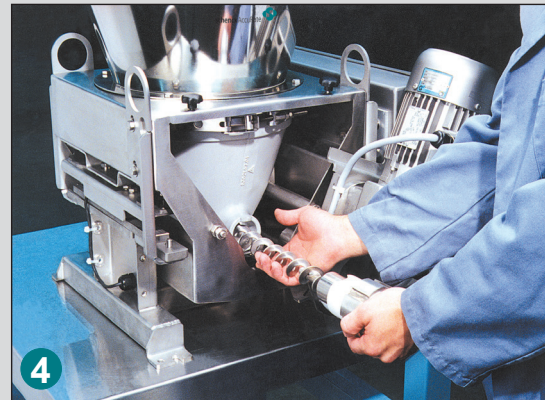

4 Helix is easily removed allowing for fast helix style and diameter changes.



5 Release band clamp for easy hopper removal. Hopper simply slides out for cleaning, replacement, or maintenance.



6 Replace components, reposition motor and drive assembly, tighten quill nut, replace backplate and you're ready to run – all in under two minutes.

Dimensions

EQUIPMENT CONFIGURATION	WEIGHT	HOPPER CAPACITY
Feeder (dead load).....	94 lbs. (43 kg)25 cu. ft. (7 L)
Feeder + cover (dead load).....	103 lbs. (47 kg)25 cu. ft. (7 L)
Stand + control + feeder + cover (total).....	160 lbs. (73 kg)25 cu. ft. (7 L)
Feeder + 1 cu. ft. (30 L) extension hopper + cover (dead weight).....	113 lbs. (51 kg)	1.30 cu. ft. (37 L)
Stand + feeder + 1 cu. ft. (30 L) extension hopper + cover (total).....	176 lbs. (80 kg)	1.30 cu. ft. (37 L)
Feeder + 2.3 cu. ft. (65 L) extension hopper + cover (dead weight)....	125 lbs. (57 kg)	2.50 cu. ft. (72 L)
Stand + feeder + 2.3 cu. ft. (65 L) extension hopper + cover (total)....	188 lbs. (85 kg)	2.50 cu. ft. (72 L)
Feeder + 3 cu. ft. (83 L) extension hopper + cover (dead weight).....	123 lbs. (56 kg)	3.30 cu. ft. (90 L)
Stand + feeder + 3 cu. ft. (83 L) extension hopper + cover (total).....	186 lbs. (85 kg)	3.30 cu. ft. (90 L)

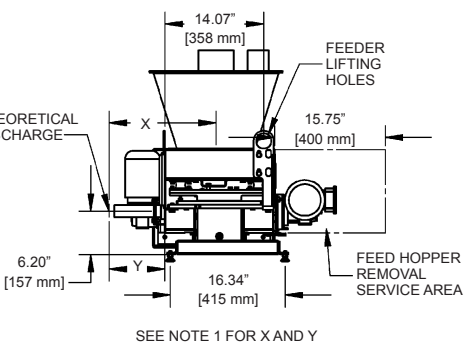
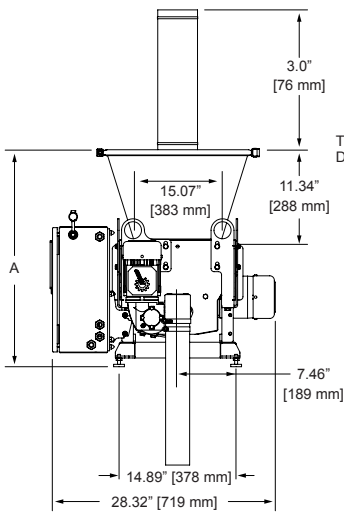
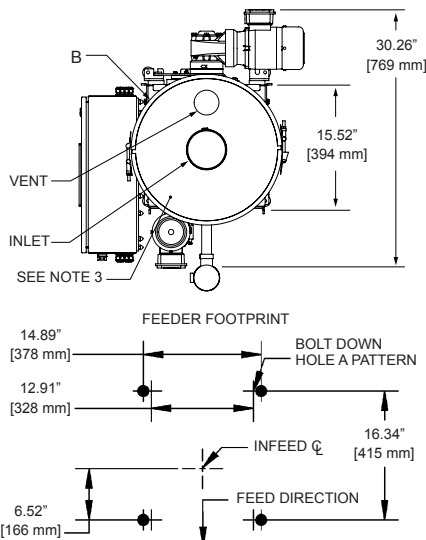

NOTES:
 1. Standard infeed to discharge (X) is 15" (385 mm). Standard distance from front face of feeder (Y) is 7" (178 mm). Extensions are available in one inch increments to the maximums stated below:

EXTENSION HOPPER DIMENSIONS

Capacity	Dim "A"	Dim "B"
1.0 cu. ft. (30 L)	26.2" (666 mm)	18.9" (481 mm)
2.3 cu. ft. (65 L)	37.2" (945 mm)	18.9" (481 mm)
3.0 cu. ft. (83 L)	35.7" (906 mm)	24.9" (633 mm)

Helix Dia.	Max. Infeed to Dis. (X)	Max. FFOF (Y)
.25-.75" (6.4-19 mm)	19.7" (500 mm)	12" (305 mm)
1" (25 mm)	43.7" (1,100 mm)	36" (915 mm)
1.38" (35 mm)	55.7" (1,500 mm)	48" (1,220 mm)

NOTE: Overall height of feeder is increased by .5" (12.7 mm) to 1.25" (31.8 mm) when using optional leveling feet.

- System scale capacity:
 Total (2 Load Cells)
 132 lbs. (60 kg) 264 lbs. (120 kg) 441 lbs. (200 kg)
- Cover is available in auto refill (shown), manual refill or with no cover. Cover may be rotated up to 360° to meet application requirements.
 Standard inlet and vents:
 For 1 cu. ft. (30 L) & 2.3 cu. ft. (65 L) hoppers =
 5" (127 mm) inlet & 3" (76 mm) vent
 For 3 cu. ft. (83 L) hoppers =
 10" (254 mm) inlet & 4" (102 mm) vent

Schenck Process
 746 E. Milwaukee Street
 Whitewater, WI 53190
 262-473-2441
 sales-fcp@schenckprocess.com
 www.schenckprocess.com/us

- Electrical service requirements:
 230V, 3 phase, 16.2 amps max. full load current, 50/60 Hz
 -or- 460V, 3 phase, 7.1 amps max. full load current, 50/60 Hz



All information is given without obligation. All specifications are subject to change. © by Schenck Process, 2021